

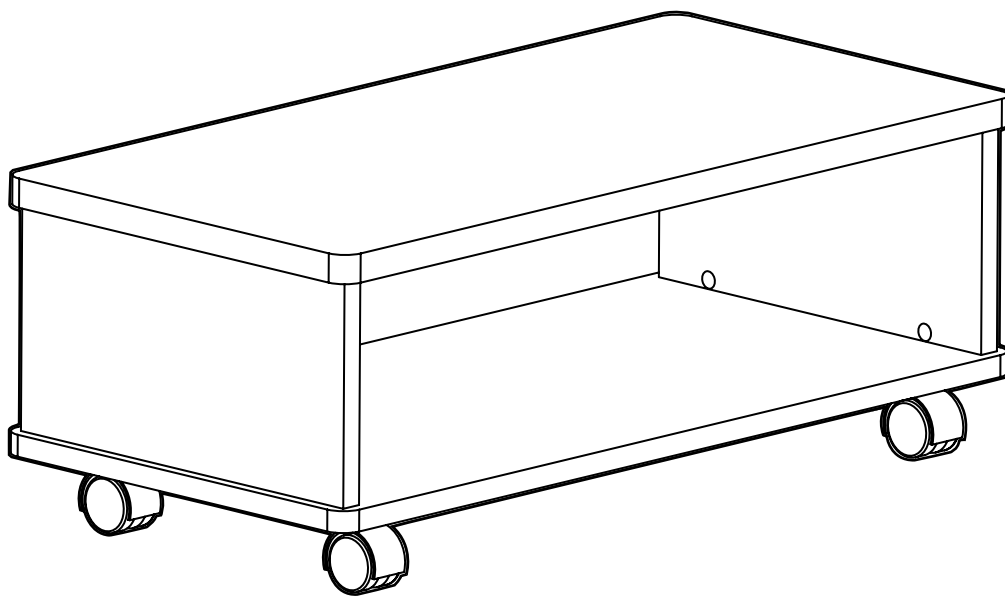

WG32

PRINTER WAGON



IMPORTANT!

Assembly may require the assistance of another person.

Before you begin assembly:

READ THE DIRECTIONS all the way through one time. This will speed up the process and help you understand the sequence of steps.

COUNT THE PARTS AND HARDWARE before assembly. This ensures you have received all necessary parts before you begin.

TOOLS: You may need a Phillips head screwdriver, a medium slotted screwdriver or a plastic mallet. To protect your new furniture from damage during assembly, it is recommended to work on a carpeted surface.

In the event any parts are missing from this package, send your name, address, telephone number, and a description of the missing part(s) to: **PARTS, Box 1420, Missoula, MT 59806** or call: **1-800-769-5693** or **FAX 1-800-445-5281**.

CAUTION: On assemblies requiring glue, make sure the unit is assembled correctly before gluing. Once this unit is assembled with glue, the manufacturer will not be responsible for damaged parts. Keep a damp cloth or sponge handy to wipe off excess glue.

To care for this furniture, simply wipe with a cloth dampened with glass cleaner containing ammonia-D.

PARTS & HARDWARE DIAGRAM

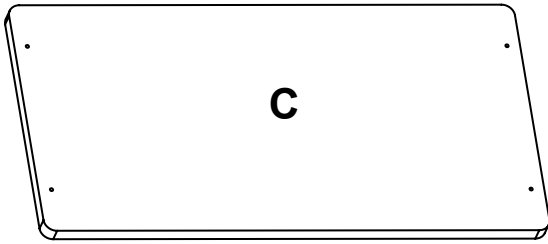

Top	05830801	1 ea.
-----	----------	-------

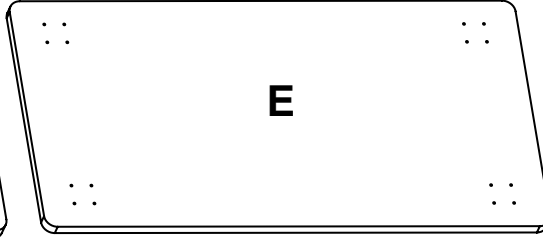

Bottom	05830811	1 ea.
--------	----------	-------

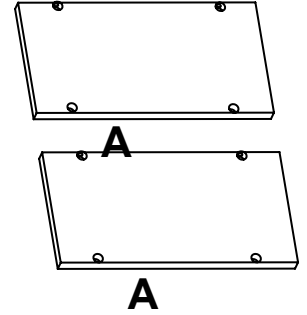

Sides	05830841	1 ea.
-------	----------	-------

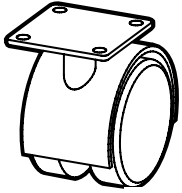

H1	Plate Caster	402050	4 ea.
----	--------------	--------	-------



H2	8x5/8 Phillips Panhead Screw	988056	16 ea.
----	------------------------------	--------	--------

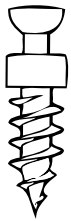

H3	Rafix Bolt	909925	8 ea.
----	------------	--------	-------



H4	Flush Rafix Cam	909911	8 ea.
----	-----------------	--------	-------

Using the Rafix System:

Insert the Rafix Cams into the appropriate holes. The flat edge of the cam should be facing the edge of the panel.

Slide Rafix Cams of the panel to be attached onto the corresponding posts.

When screwing post into hole, **Do Not** over tighten. Screw post down until bottom face of post flange just touches board surface.

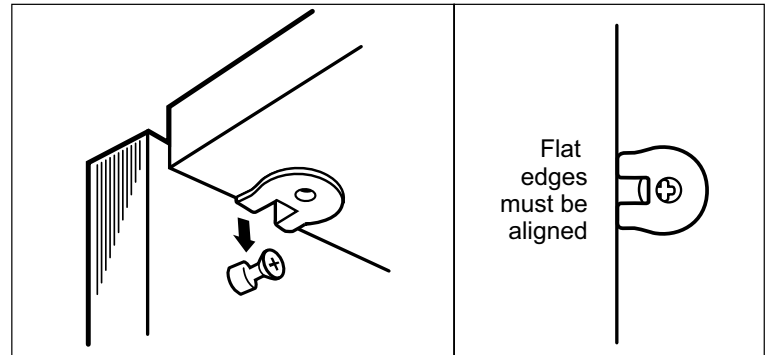
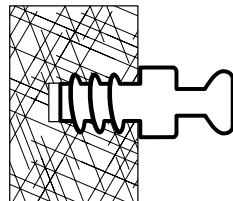

Using a #3 Phillips screwdriver, turn the rotating portion of the Rafix Cam a 1/2 turn clockwise to secure. **IMPORTANT!** Do not exceed 1/2 turn when tightening cams. Turn 1/2 turn counterclockwise to disassemble and remove panel.

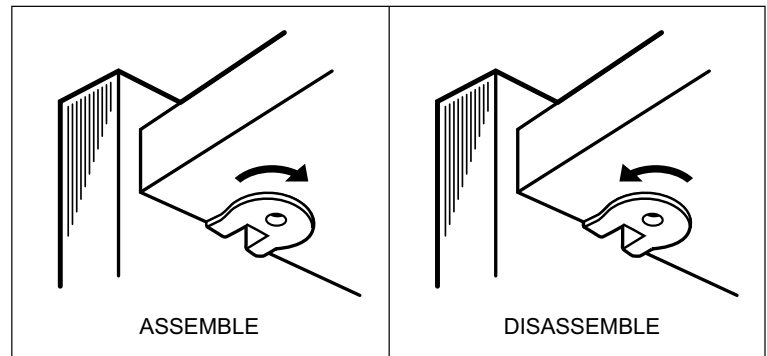

#1

Place the Bottom Panel (E) face down on a clean, carpeted surface with the pre-drilled holes facing up. Install four Plate Casters (H1) at each corner of the Bottom using Panhead Screws (H2) in the pre-drilled holes as shown.

Place the two locking casters toward the front.

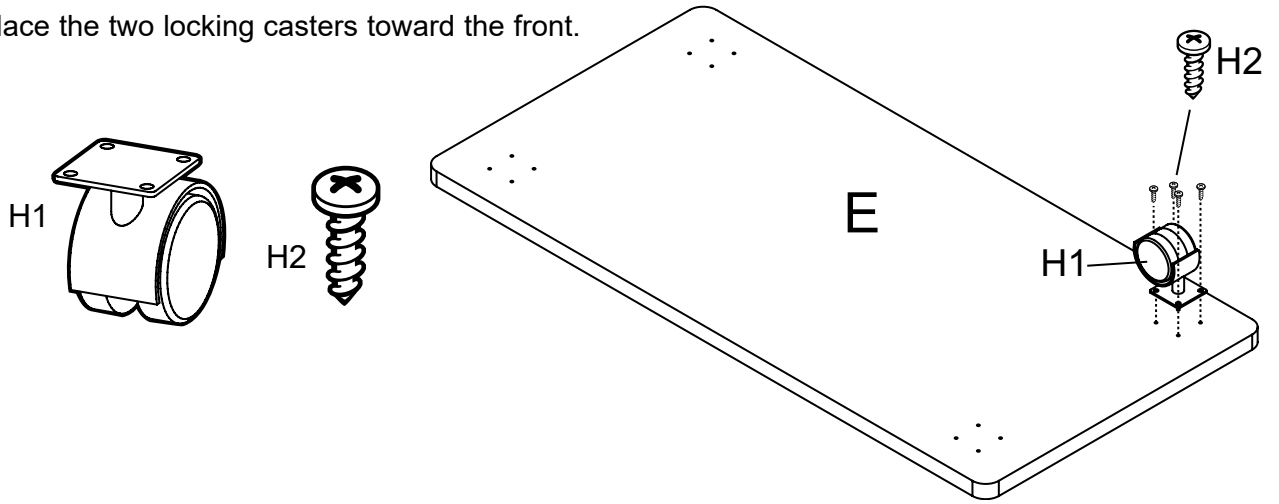

#2

Turn the Bottom (E) upright. Place the Top (C) face down with the pre-drilled holes facing up. Screw four Rafix Bolts (H3) into the pre-drilled holes on the Bottom and four Rafix Bolts into the pre-drilled holes on the Top.

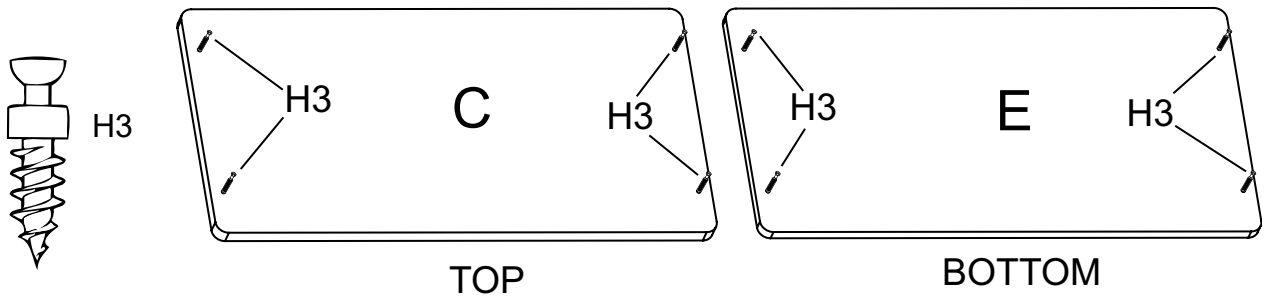

#3

Insert four Flush Rafix Cams (H4) into each Side (A).

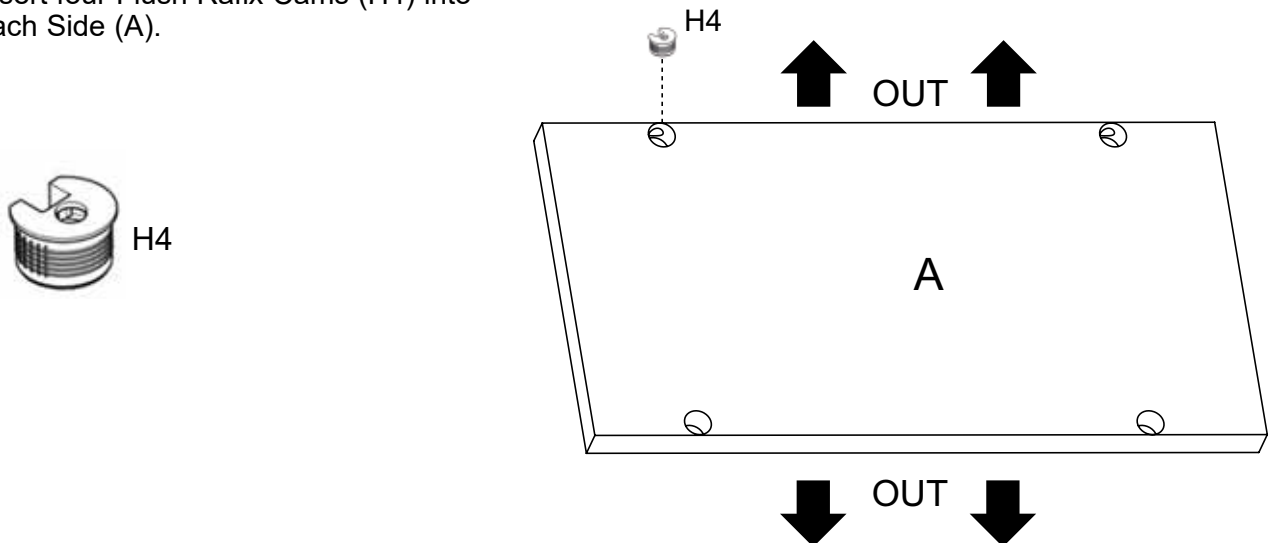

#4

Fit the Sides (A) over the Rafx Bolts (H3) already installed on the Bottom (E). Using a Phillips screwdriver, rotate the Flush Rafx Cams (H4) clockwise to secure in place.

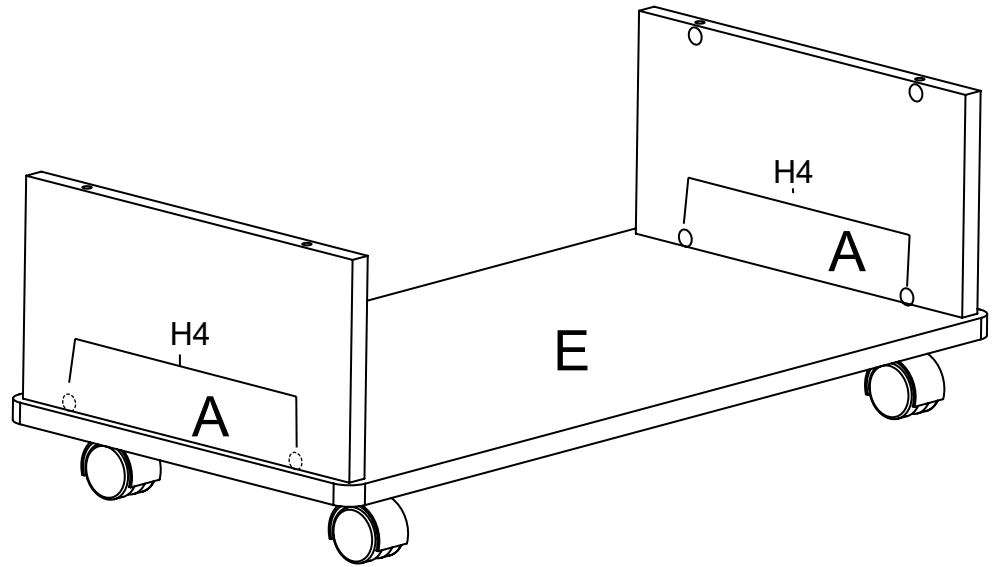

#5

Place the Top (C) onto the sides, seating the Rafx Bolts of the Top into the Cam sockets on the Sides. Using a Phillips screwdriver, rotate the Cams clockwise to secure the top to the sides.

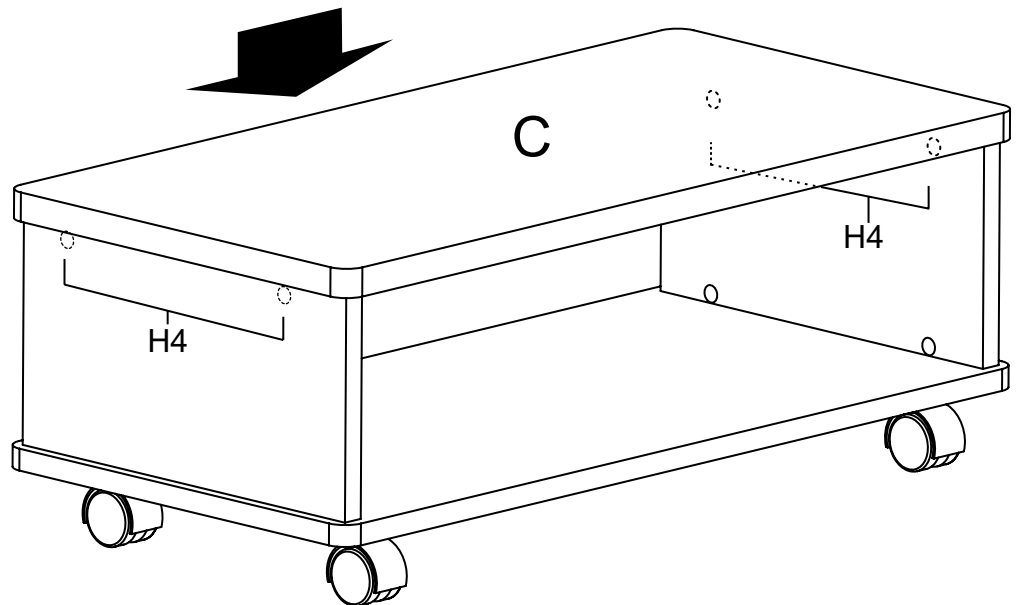

Your Printer Wagon is now assembled and ready for use.