

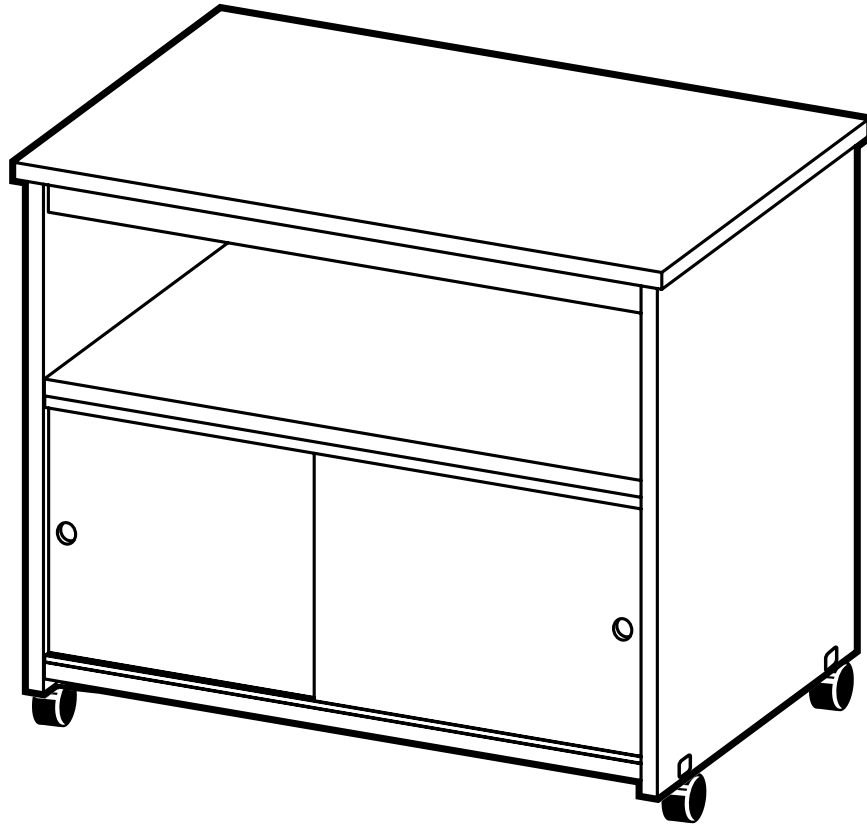

IRONWOOD

MPS

MULTI-PURPOSE STAND



IMPORTANT!

Assembly may require the assistance of another person.

Before you begin assembly:

READ THE DIRECTIONS all the way through one time. This will speed up the process and help you understand the sequence of steps.

COUNT THE PARTS AND HARDWARE before assembly. This ensures you have received all necessary parts before you begin.

TOOLS: You may need a Phillips head screwdriver, a medium slotted screwdriver or a plastic mallet. To protect your new furniture from damage during assembly, it is recommended to work on a carpeted surface.

In the event any parts are missing from this package, send your name, address, telephone number, and a description of the missing part(s) to: **PARTS, Box 1420, Missoula, MT 59806** or call: **1-800-769-5693** or **FAX 1-800-445-5281**.

CAUTION: On assemblies requiring glue, make sure the unit is assembled correctly before gluing. Once this unit is assembled with glue, the manufacturer will not be responsible for damaged parts. Keep a damp cloth or sponge handy to wipe off excess glue.

To care for this furniture, simply wipe with a cloth dampened with glass cleaner containing ammonia-D.

PARTS DIAGRAM

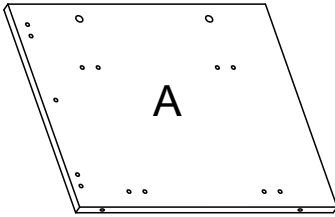

Left Side	05850641	1 ea.
-----------	----------	-------

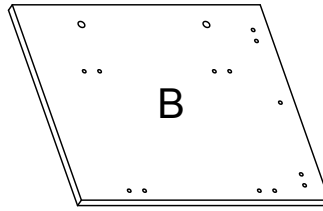

Right Side	05850641	1 ea.
------------	----------	-------

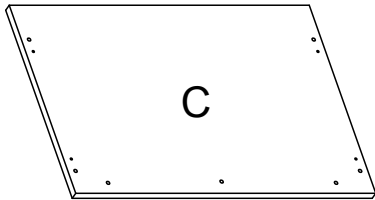

Top	05850601	1 ea.
-----	----------	-------

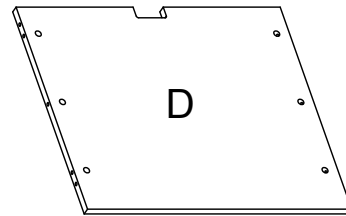

Back	05850652	1 ea.
------	----------	-------

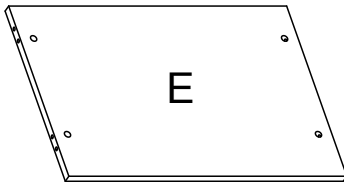

Bottom	05850611	1 ea.
--------	----------	-------

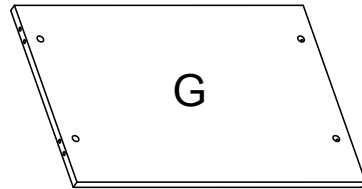

Shelf	05850611	1 ea.
-------	----------	-------



Left Door	05850673	1 ea.
-----------	----------	-------

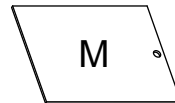

Right Door	05850673	1 ea.
------------	----------	-------

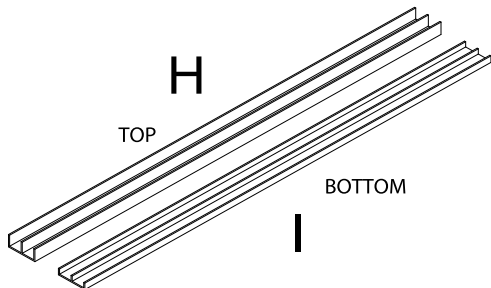

Top Door Slide	H0045	1 set
Bottom Door Slide	H0055	

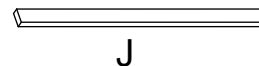

Facia	05850686	1 ea.
-------	----------	-------

HARDWARE

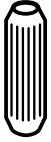

H1	Wood Dowel	195000	19 ea.
----	------------	--------	--------



H2	Minifix Bolt	909834	18 ea.
----	--------------	--------	--------



H3	Minifix Cam	909810	18 ea.
----	-------------	--------	--------

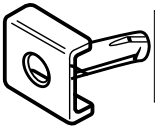

H4	Socket Bracket	402301	4 ea.
----	----------------	--------	-------



H5	Casters (2 locking)	402290	1 set
----	------------------------	--------	-------



H6	Finger Pull	290110	2 ea.
----	-------------	--------	-------



H7	Glue	295020	1 ea.
----	------	--------	-------

Using the Minifix System:

Insert the Minifix Cams into the appropriate holes with the arrow facing outwards as shown.

When screwing post into hole, **Do Not** over tighten. Screw post down until bottom face of post flange just touches board surface.

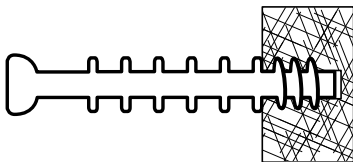

Using the #2 Phillips screwdriver, rotate the Cam Devices a half turn clockwise until snug.

To disassemble, turn the Cam Devices counter-clockwise and remove panels.

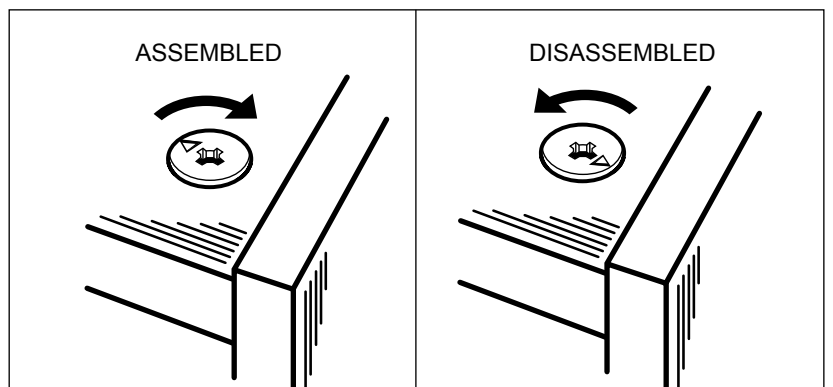
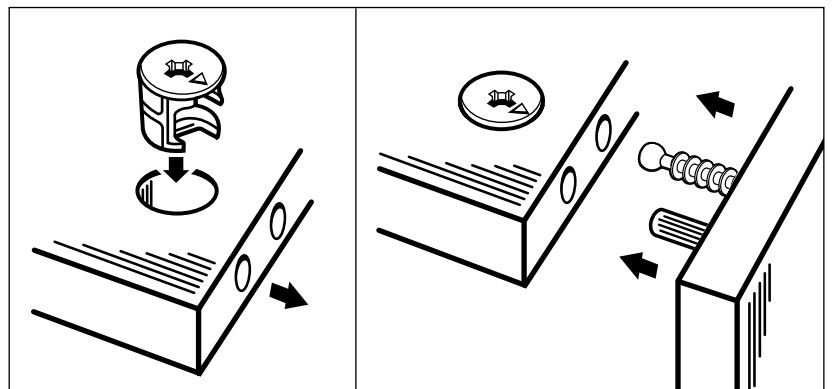

#1

Glue three Wood Dowels (H1) into the top of the Facia Strip (J) as shown. Fill each hole 1/4" full of glue and tap Wood Dowels into hole until bottomed out.

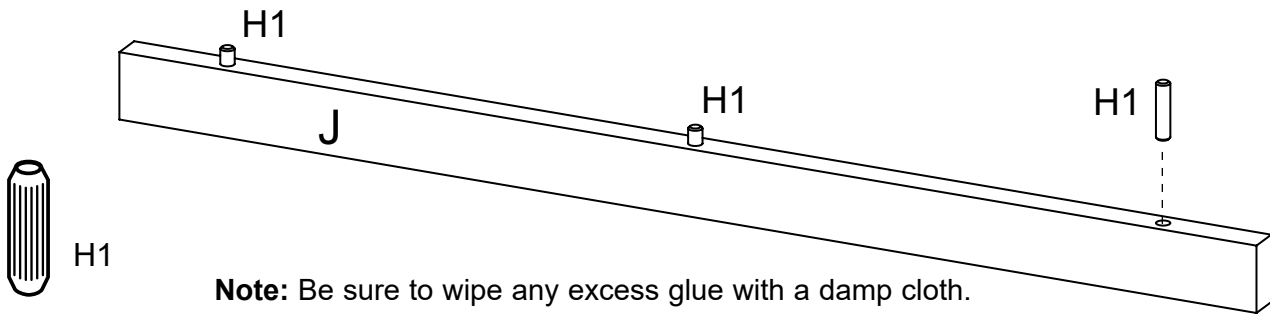

#2

Glue the Facia Strip (J) to the underside of the Worksurface (C) as shown. Fill each hole 1/4" full of glue and press Facia Strip until fully seated in place. Set aside to dry.

Note: Be sure to wipe any excess glue with a damp cloth.

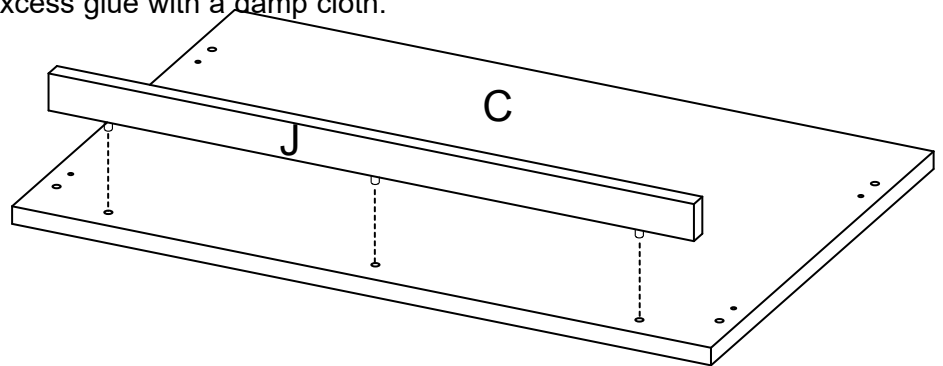

#3

Screw 4 Minifix Bolts (H2) into the pre-drilled holes of the Worksurface (C) where indicated.

Insert 4 Wood dowels (H1) into Worksurface (C) where indicated.

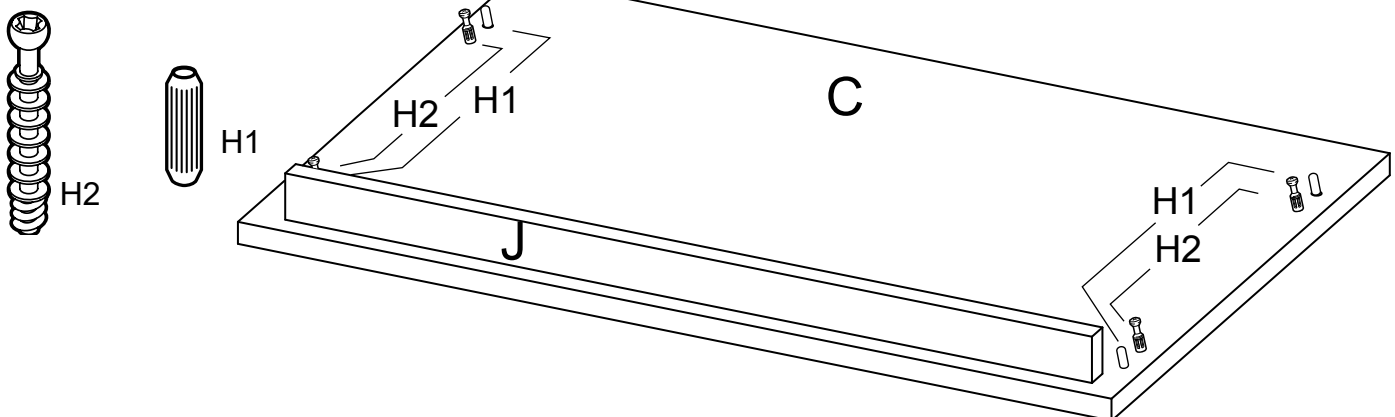

#4

Screw 7 Minifix Bolts (H2) into the pre-drilled holes of the Left Side (A) and the Right Side (B) where indicated.

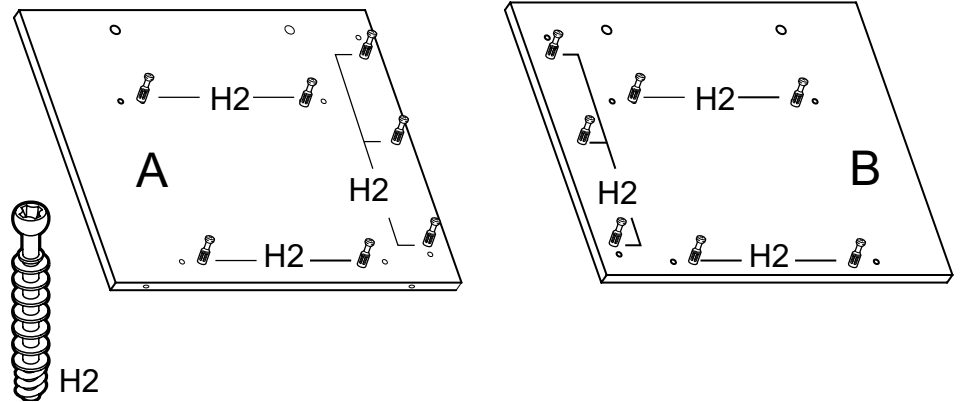

#5

Insert 6 Wood Dowels (H1) into the pre-drilled holes of the Left Side (A) and the Right Side (B) where indicated.

Insert 2 Minifix Cams (H3) facing out into Left Side (A) and Right Side (B) as shown.

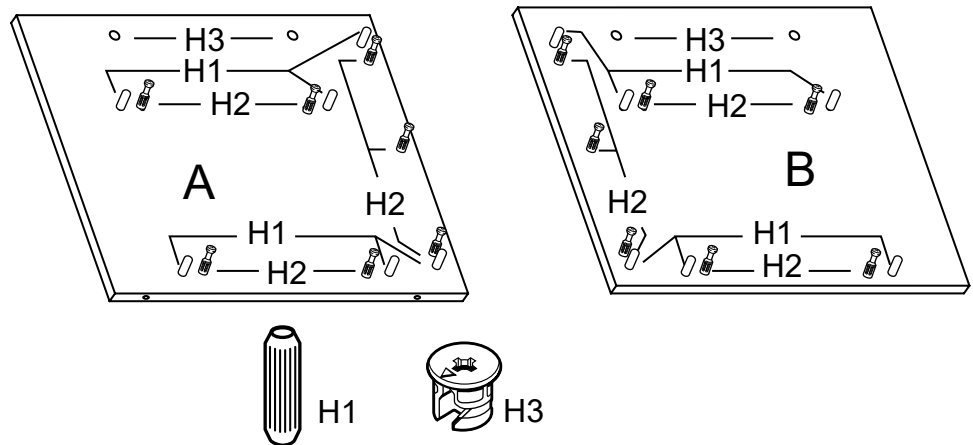

#6

Place Socket Brackets (H4) over the holes in the bottom and tap until bottomed out against the wood.

Insert Casters (H6) into the Caster Sockets (H5) and tap into place as shown.

Note: the locking Casters should be installed to the front of the unit.

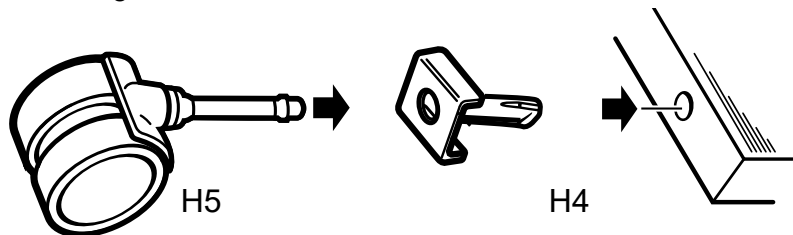

#7

Insert 7 Minifix Cams (H3) into the Back (D) facing out. Position Back over posts and dowels of the Left Side (B) as shown.

Rotate Cams clockwise to lock in place.

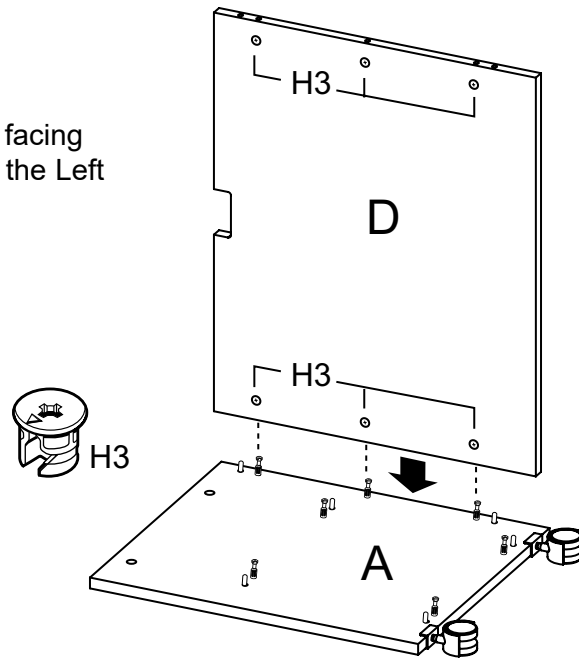

#8

Insert 4 Minifix Cams (H3) into the Shelf (G). Position Shelf onto the Left Side (A) as shown.

Rotate Cams clockwise to lock in place.

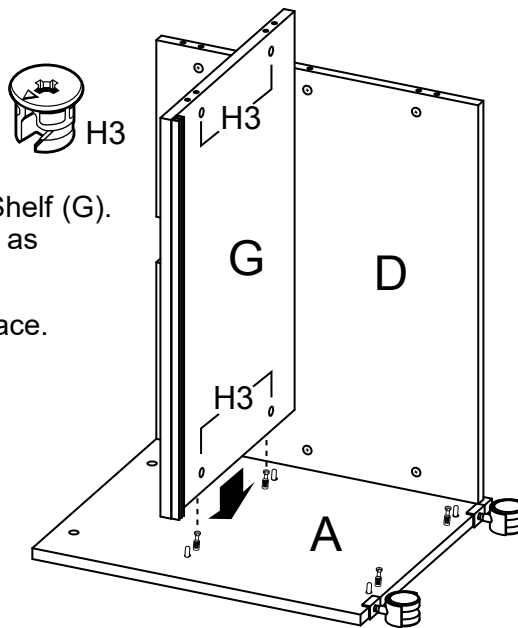

#9

Insert 4 Minifix Cams (H3) into the Bottom Panel (E) facing out. Position Bottom onto unit as shown.

Rotate Cams clockwise to lock in place.

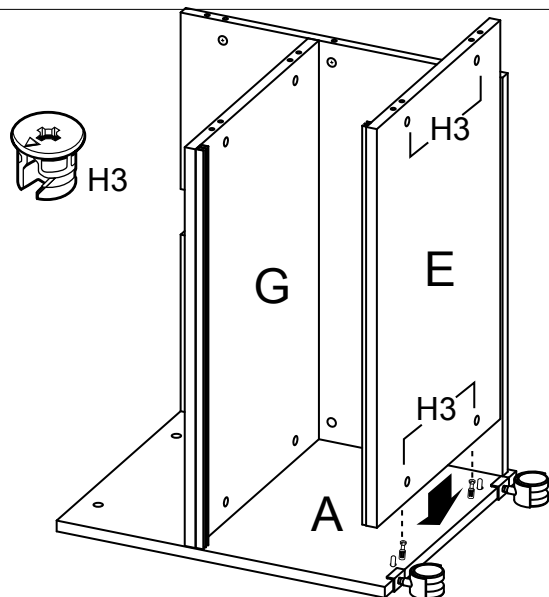

#10

Position Right Side (B) bolts and dowels over the corresponding Cams of the unit as shown.

Rotate Cams clockwise to lock in place.

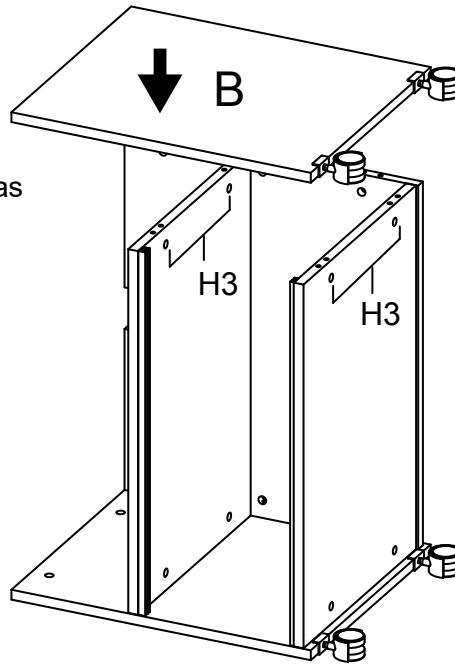

#11

Turn the unit upright. Position Worksurface (C) bolts and dowels onto the corresponding Cams of the unit as shown.

Rotate Cams clockwise to lock in place.

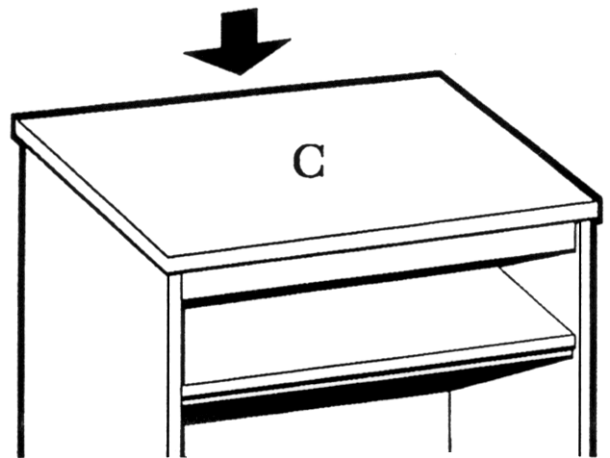

#12

Press a Finger Pull (H6) into the hole on the finished side of each Door as shown.

Identify the Left and Right doors. The Left Door (L) is wider than the Right Door (M).

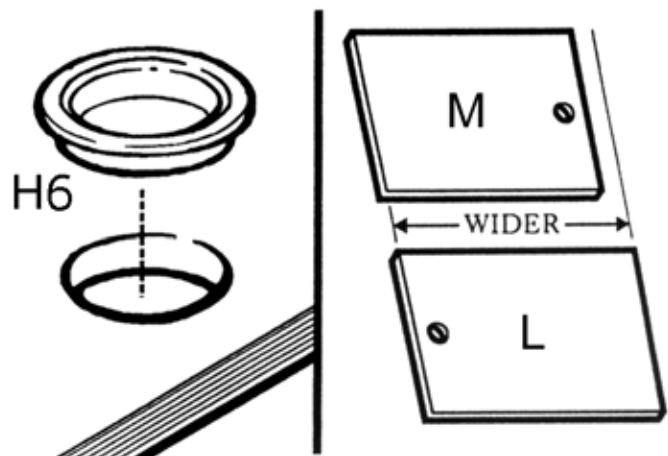

#13

Due to excessive breaking during shipping, we are no longer pre-installing the door track.

First, remove paper backing from adhesive strip on the large door track (H). Place the track on the underside of Shelf (E) 1/4" from the front edge.

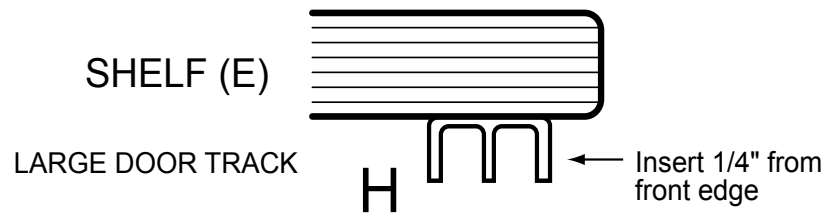

Next, remove paper backing from adhesive strip on the small door track (I). Place the track on the top of Bottom (D) 1/4" from the front edge.

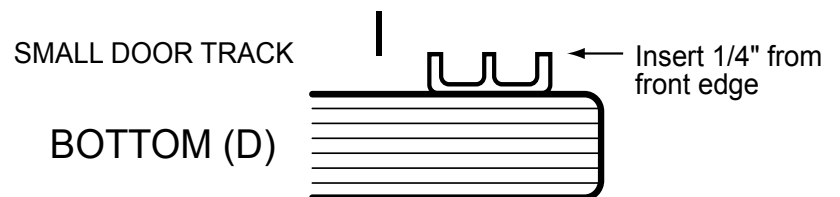

#14

Install Left door (L) into the rear door tracks as shown. Insert the upper edge of the Door into the top rear channel, pivot the door down and into lower rear channel as shown.

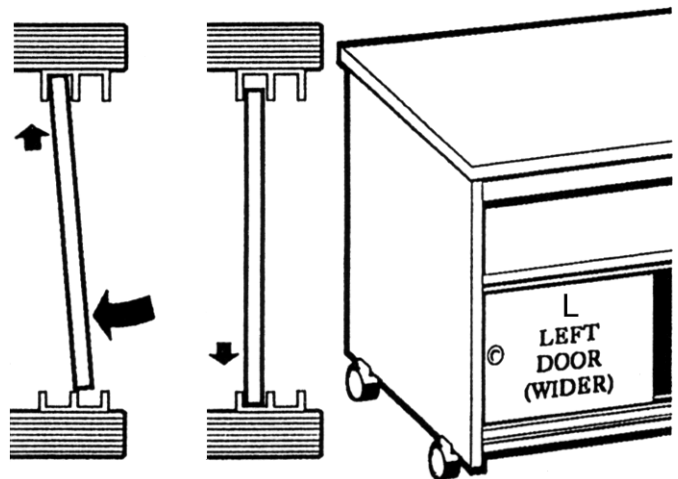

#15

Install Right door (M) into the front door track in the same manner.

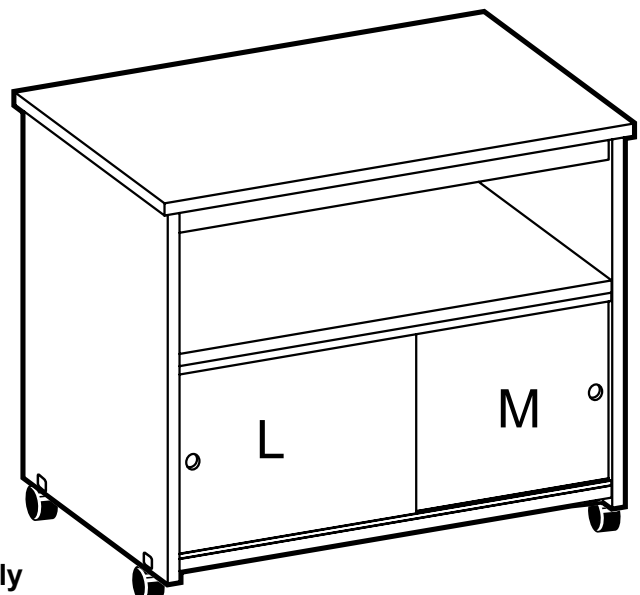

Your MPS Multi Purpose Stand is now completely assembled and ready for use.