

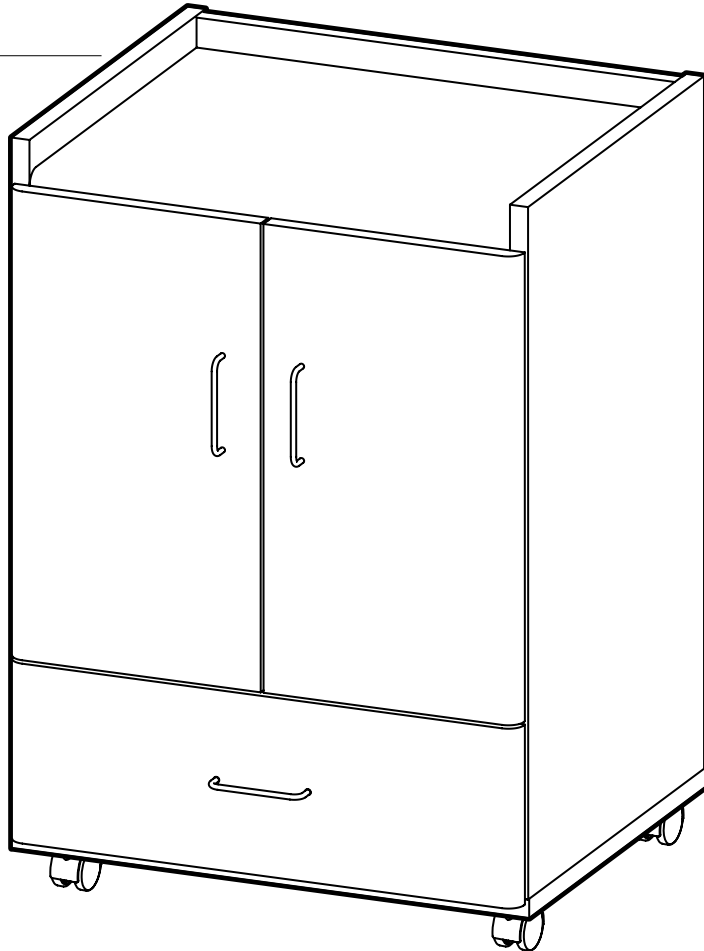

# IRONWOOD

## CB1

### COFFEE BAR



### IMPORTANT!

Assembly may require the assistance of another person.

Before you begin assembly:

**READ THE DIRECTIONS** all the way through one time. This will speed up the process and help you understand the sequence of steps.

**COUNT THE PARTS AND HARDWARE** before assembly. This ensures you have received all necessary parts before you begin.

**TOOLS:** You may need a Phillips head screwdriver, a medium slotted screwdriver or a plastic mallet. To protect your new furniture from damage during assembly, it is recommended to work on a carpeted surface.

In the event any parts are missing from this package, send your name, address, telephone number, and a description of the missing part(s) to: PARTS, Box 1420, Missoula, MT 59806 or call: 1-800-769-5693 or FAX 1-800-445-5281.

**CAUTION:** On assemblies requiring glue, make sure the unit is assembled correctly before gluing. Once this unit is assembled with glue, the manufacturer will not be responsible for damaged parts. Keep a damp cloth or sponge handy to wipe off excess glue.

To care for this furniture, simply wipe with a cloth dampened with glass cleaner containing ammonia-D.

# PARTS DIAGRAM

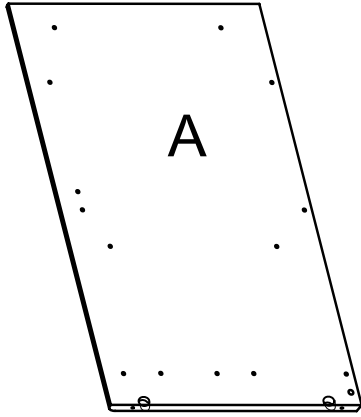

Left Side	05850341	1 ea.
-----------	----------	-------

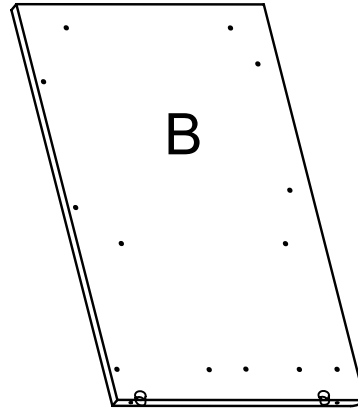

Right Side	05850341	1 ea.
------------	----------	-------

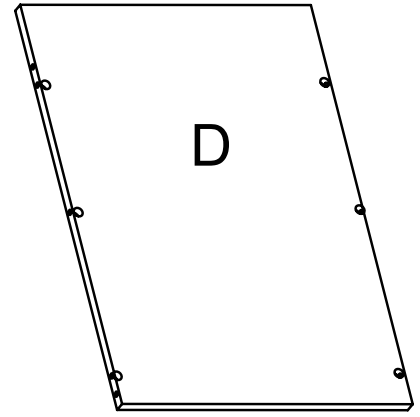

Back	05850352	1 ea.
------	----------	-------

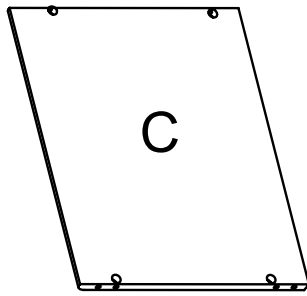

Top	05850301	1 ea.
-----	----------	-------

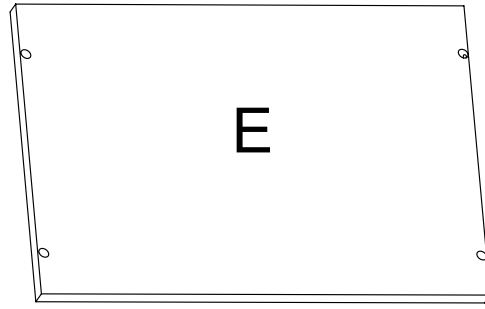

Bottom	05850311	1 ea.
--------	----------	-------

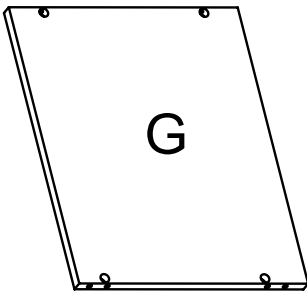

Shelf	05850311	1 ea.
-------	----------	-------

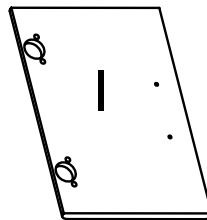

Doors	05850373	2 ea.
-------	----------	-------

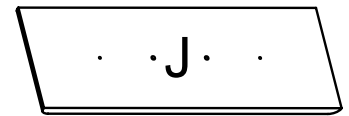

Drawer Front	05850363	1 ea.
--------------	----------	-------

D1

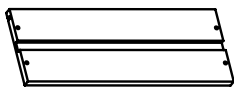

Drawer Sides	069270	2 ea.
--------------	--------	-------

D2

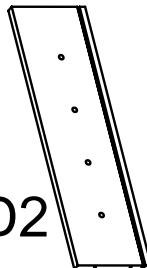

Drawer Front/Back	069070	2 ea.
-------------------	--------	-------

D5

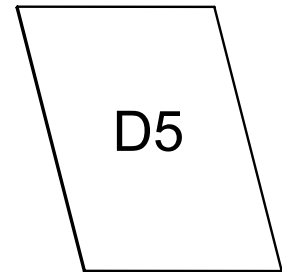

Drawer Bottom	191665	1 ea.
---------------	--------	-------

# HARDWARE



H1	Flush Rafix Cam	909911	10 ea.
----	-----------------	--------	--------



H2	Rafix Bolt	909925	18 ea.
----	------------	--------	--------



H3	Rafix Cam	909910	8 ea.
----	-----------	--------	-------

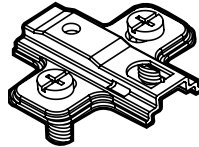

H4	Hinge Plate	400201	4 ea.
----	-------------	--------	-------

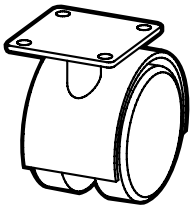

H5	Plate Caster	402050	2 ea.
----	--------------	--------	-------

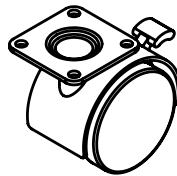

H6	Plate Caster W/ Lock	402051	2 ea.
----	----------------------	--------	-------



H7	Lg. Panhead Screws	988056	16 ea.
----	--------------------	--------	--------

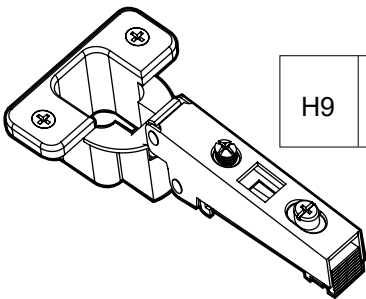

H9	Hinge	400200	4 ea.
----	-------	--------	-------

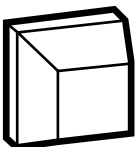

H10	Square Black Bumper	298030	4 ea.
-----	---------------------	--------	-------



H11	White Glue	295020	1 ea.
-----	------------	--------	-------



H12	Confirmat 5x50 Screws	950100	8 ea.
-----	-----------------------	--------	-------



H13	Washer Head Screws	920200	2 ea.
-----	--------------------	--------	-------

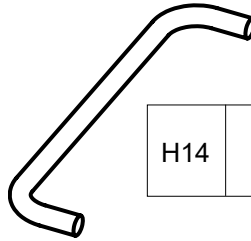

H14	Drawer/Door Pulls	200070	3 ea.
-----	-------------------	--------	-------



H15	1-1/4" Panhead Screws	901212	4 ea.
-----	-----------------------	--------	-------

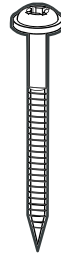

H16	1-3/4" Quad Washerhead Screws	902215	2 ea.
-----	-------------------------------	--------	-------



H17	#6 x 3/4 Gold Flathead	H2225	8 ea.
-----	------------------------	-------	-------

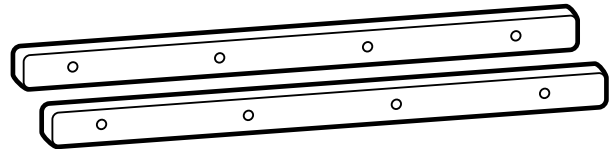

S1	Plastic Drawer Slides	267100	2 ea.
----	-----------------------	--------	-------

### Using the Rafix System:

Insert the Rafix Cams into the appropriate holes. The flat edge of the cam should be facing the edge of the panel.

Slide Rafix Cams of the panel to be attached onto the corresponding posts.

When screwing post into hole, **Do Not** over tighten. Screw post down until bottom face of post flange just touches board surface.

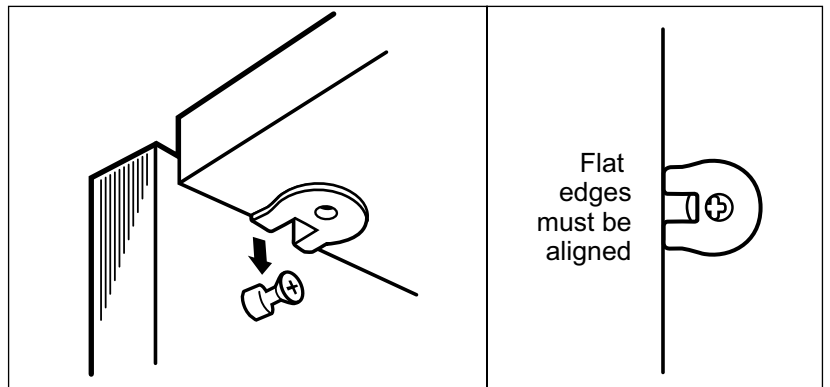
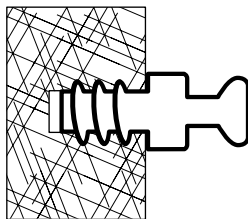

Using a #3 Phillips screwdriver, turn the rotating portion of the Rafix Cam a 1/2 turn clockwise to secure. **IMPORTANT!** Do not exceed 1/2 turn when tightening cams. Turn 1/2 turn counterclockwise to disassemble and remove panel.

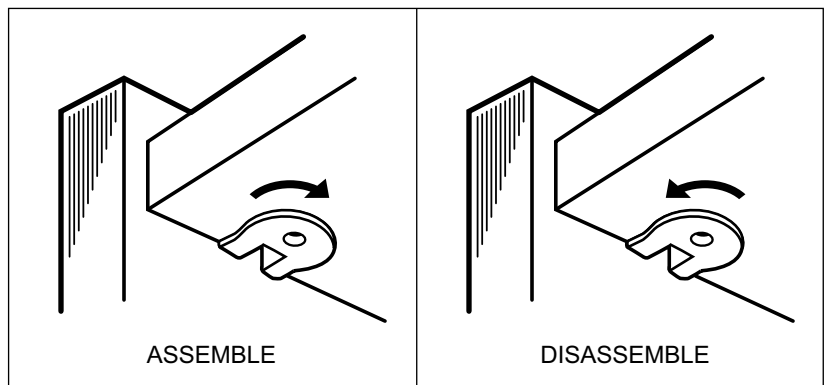

**#1**

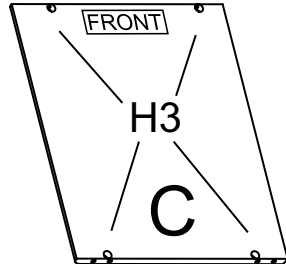
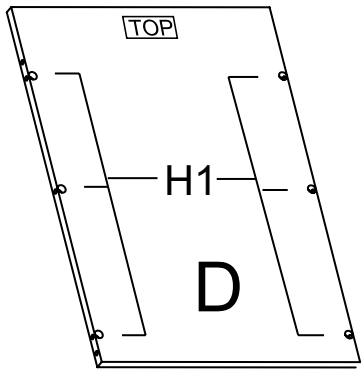

Place the Back (D) on a clean, carpeted surface as shown. Insert six Flush Rafix Cams (H1) into the Back where indicated with the arrows of the cams facing out.

Place the Top (C) on a clean, carpeted surface as shown. Insert four Rafix Cams (H3) into the Top where indicated with the arrows of the cams facing out.

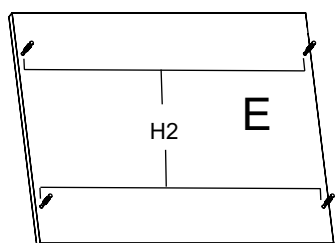
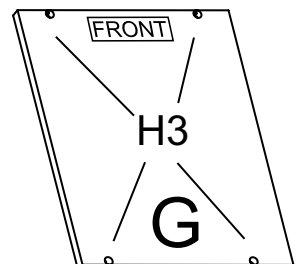

Place the Shelf (G) on a clean, carpeted surface as shown. Insert four Rafix Cams (H3) into the Shelf where indicated with the arrows of the cams facing out.

Place the Bottom (E) on a clean, carpeted surface as shown. Insert four Rafix Bolts (H2) into the bottom where indicated.

**#2**

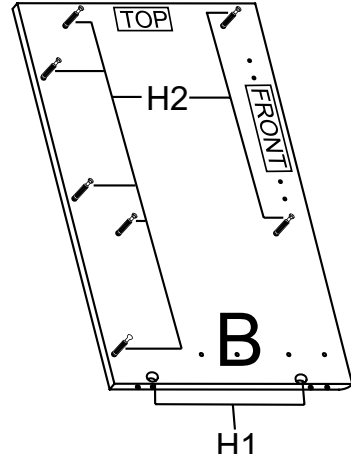
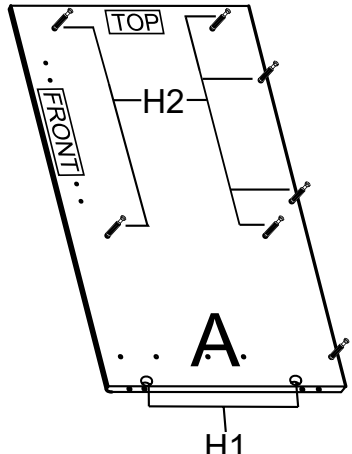

Screw nine Rafix Bolts (H2) into the Left Side (A) where indicated. Insert two Rafix Flush Cams (H1) where indicated.

Screw nine Minifix Bolts (H2) and insert eight wood Dowels (H3) into the Right Side (B) where indicated. Insert two Rafix Flush Cams (H1) where indicated.

#3

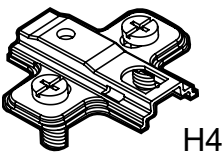

Attach Hinge Plates (H4) to Left Side (A) and Right Side (B) using the attached screws into the pre-drilled holes as shown.

**IMPORTANT!** The large hole and slots must be oriented to the rear edge of the Hinge Plates as shown.

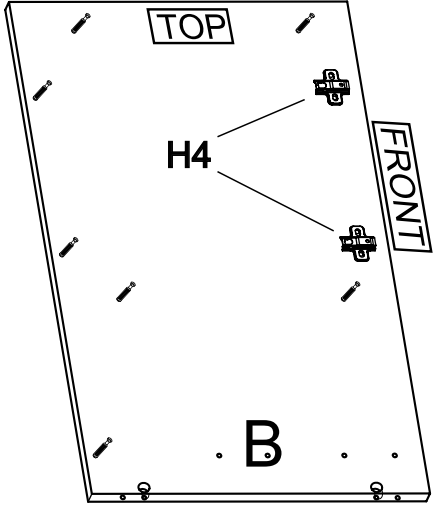
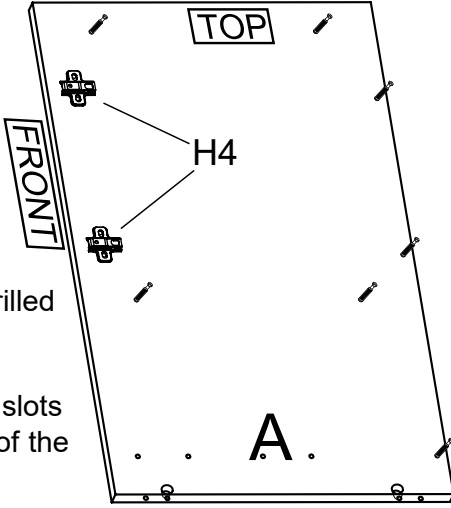

#4

Screw plastic slides in place with four Flathead Screws (H17) each.

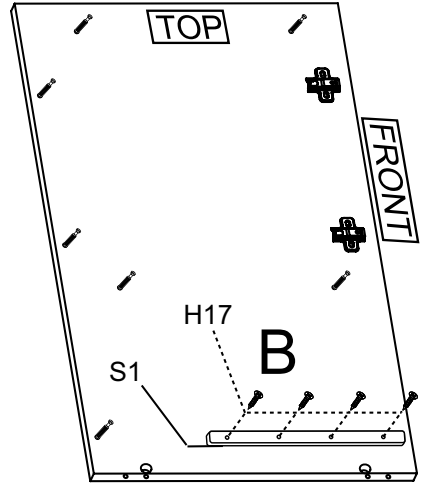
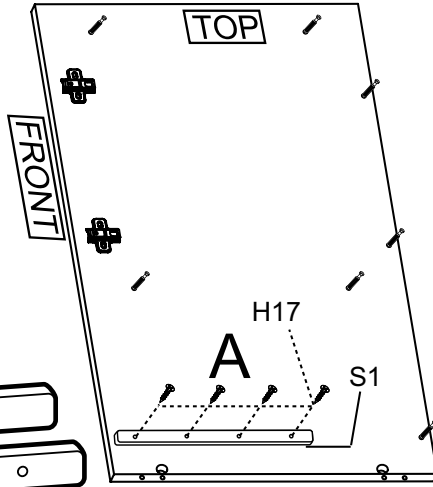
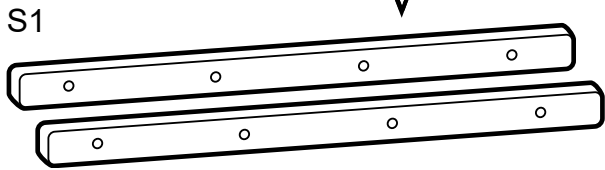
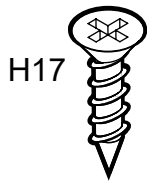

#5

Position the Back (D) onto the Left Side (A) as shown. Turn Rafix Flush Cams (H1) in the Back to secure in place.

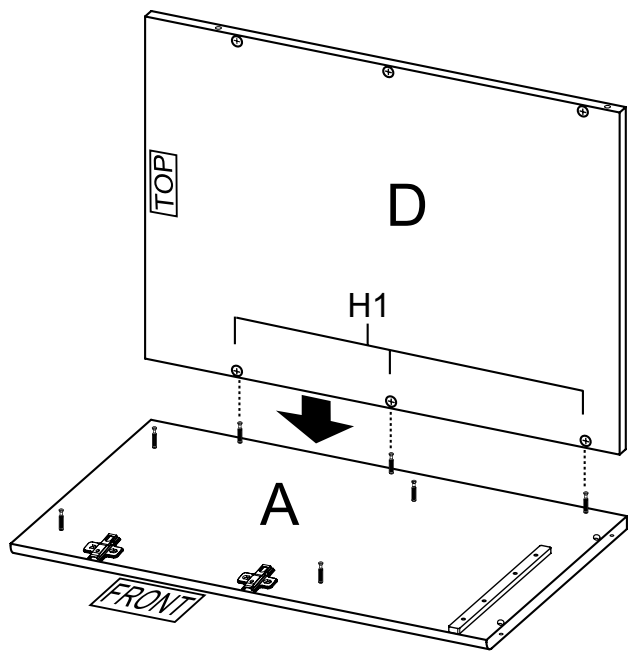

**#6**

Position the Top (C) onto the Left Side (A) as shown. Turn the Rafix Cams (H3) in the Top to secure in place.

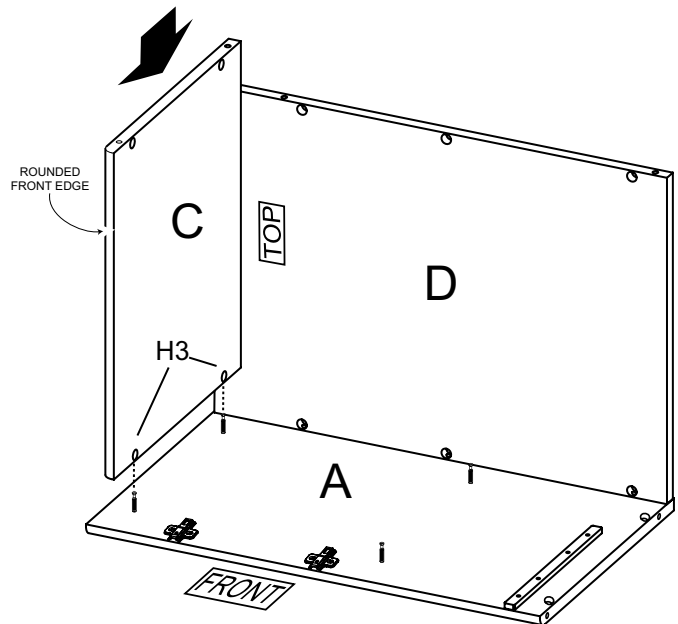

**#7**

Position the Shelf (G) onto the unit as shown. Turn the rafix cams (H3) in the Shelf clockwise to secure in place.

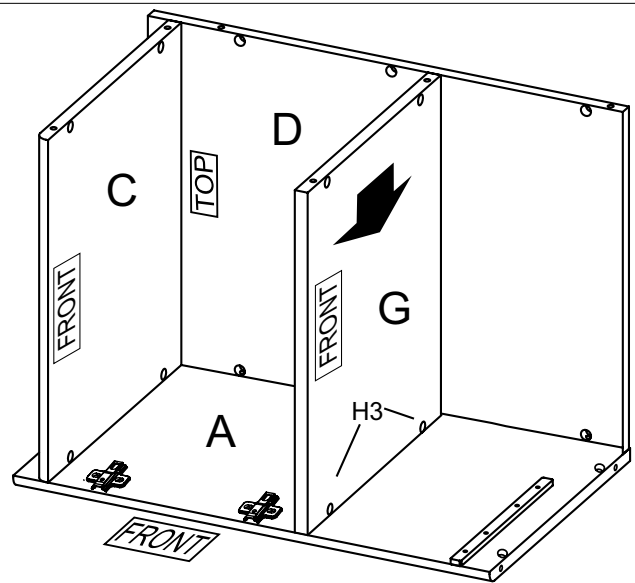

**#8**

Position Right Side (B) posts and dowels into the corresponding cams of the unit as shown.

Rotate all six Cams clockwise to lock in place.

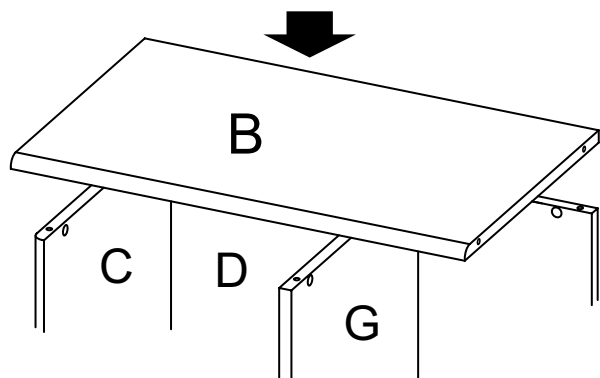

**#9**

Insert Bolts into Bottom (E) Position and secure.

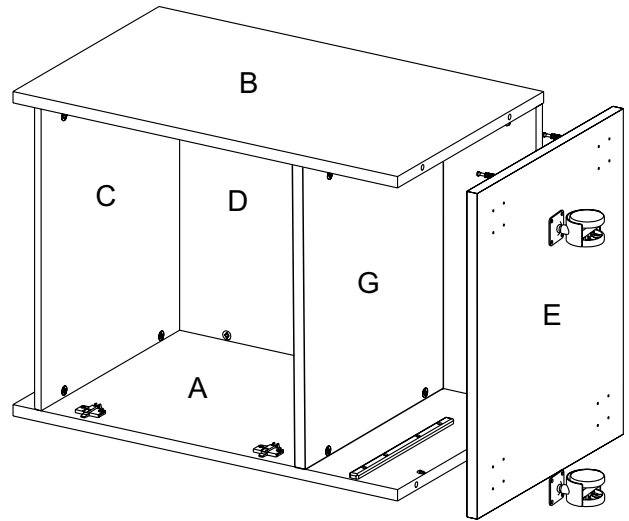

**#10**

Attach four Plate casters (H5 and H6) to the Bottom Panel (E) using the Panhead Screws in the pre-drilled holes as shown. (H7)

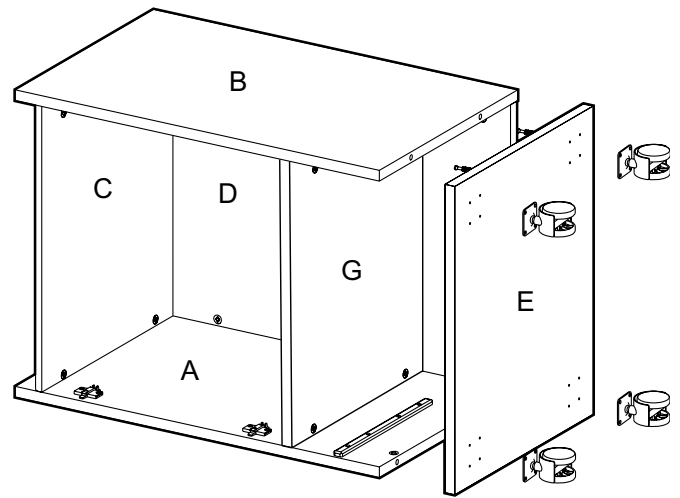
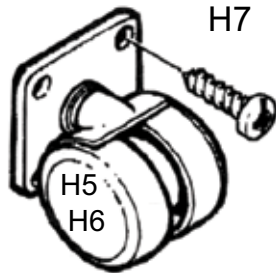

**#11**

Using a Plastic Mallet, insert the Hinges (H9) into both Doors (I).

Remove backings and press Square Black Bumpers (H10) onto the opposite corners of Doors where indicated.

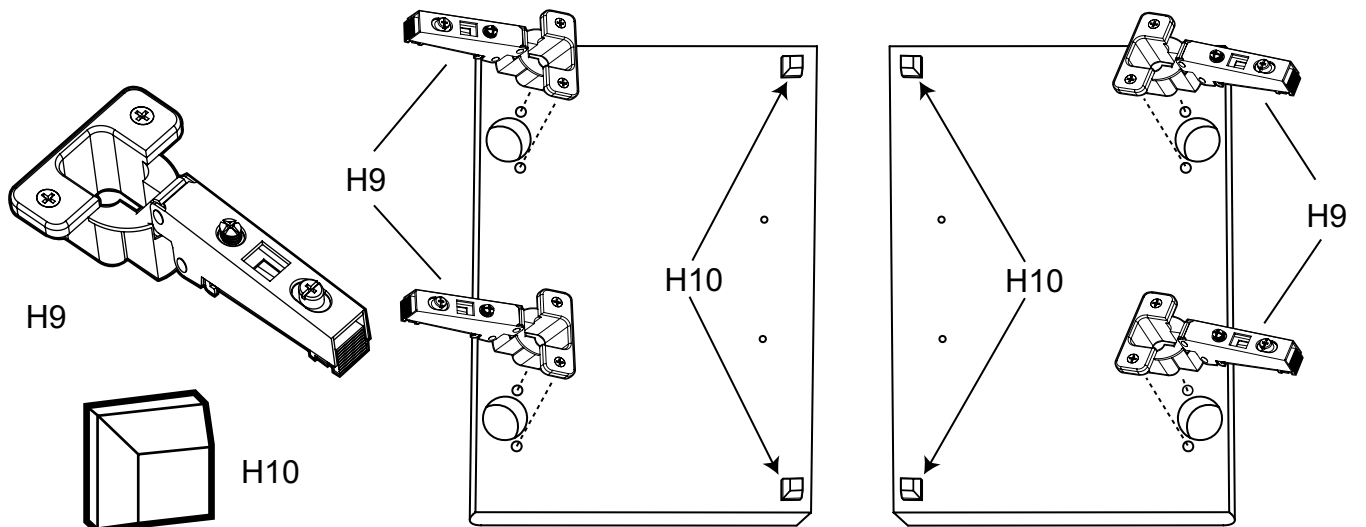

**#12**

Turn the unit upright. To attach the Doors (I) to the unit, slide the slots of the Hinges (H9) onto the Hinge Plates (H4) until the release buttons click into place.

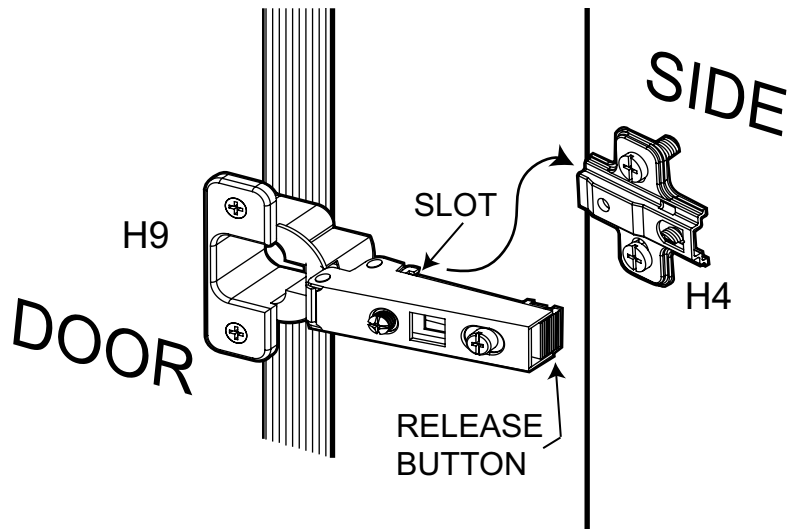

**#13**

Adjust Doors (I) to open and close easily by loosening hinge screws and repositioning Hinge as shown. Tighten hinge screws when proper alignment is achieved.

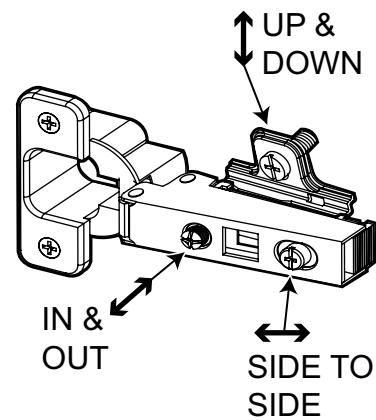

**#14**

Spread a thin layer of Glue (H11) on one edge of each Drawer End Panel (D2) as shown.

Use four Confirmat Screws (H12) to attach the Drawer End Panels to a Drawer Side (D1) with grooves aligned on the inside as shown.

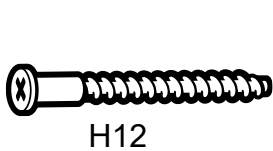

H12

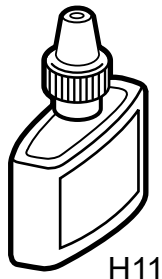

H11

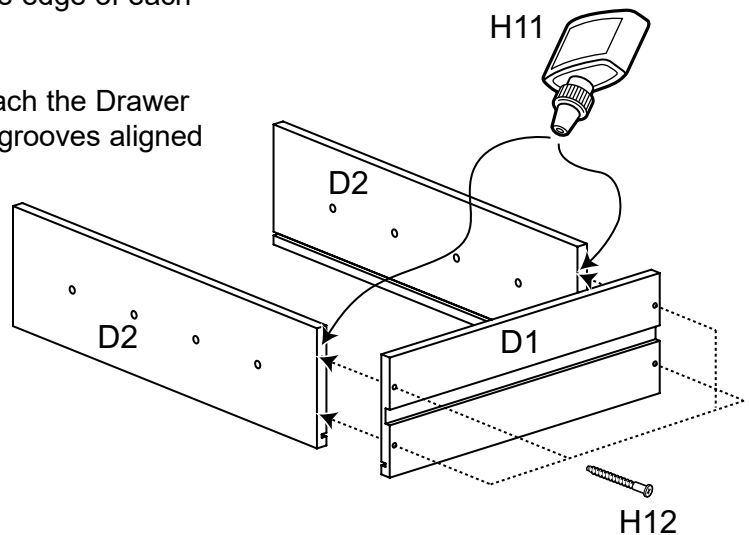

## #15

Spread a thin layer of glue on both end edges and one side edge of Drawer Bottom (D5).

Slide Drawer Bottom into the grooves of the Drawer End Panels (D2) until seated into the Drawer Side (D1) groove as shown.

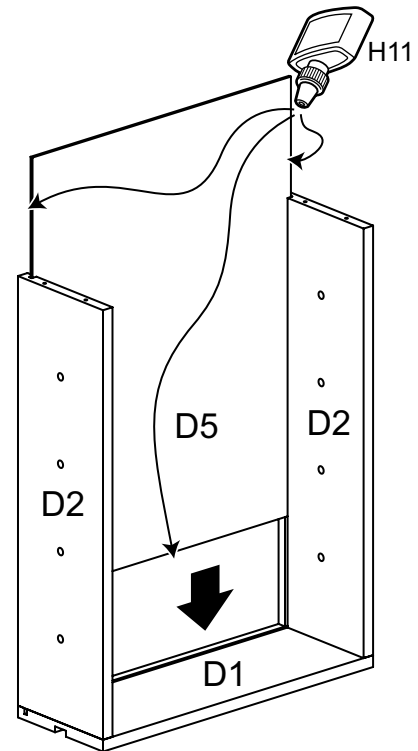

## #16

Apply glue to exposed edges of the Drawer Bottom (D5) and End Panels (D2). Position the other Drawer Side (D1) onto unit with groove aligned with the edge of the bottom.

Secure Drawer Side to Drawer End Panels using four Confirmat Screws (H12) as shown.

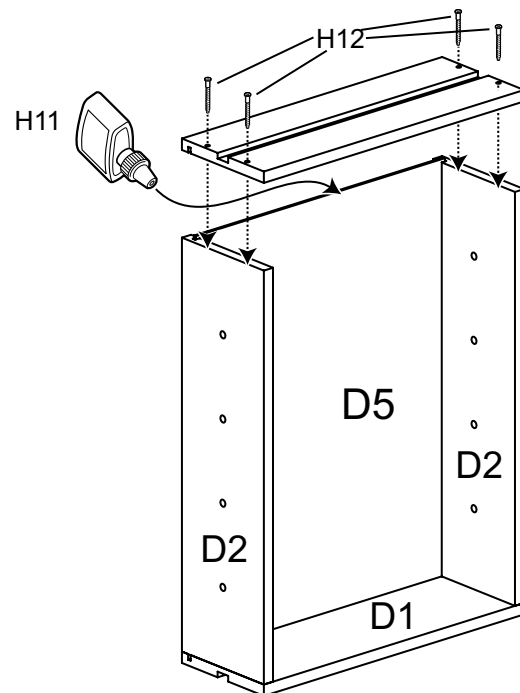
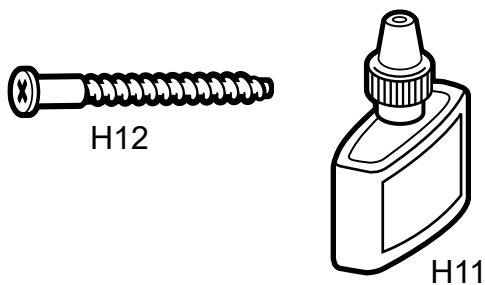

**#17**

Attach Drawer Front (J) to the Drawer unit using two Washer Head Screws (H13) in the outside holes as shown.

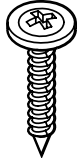

H13

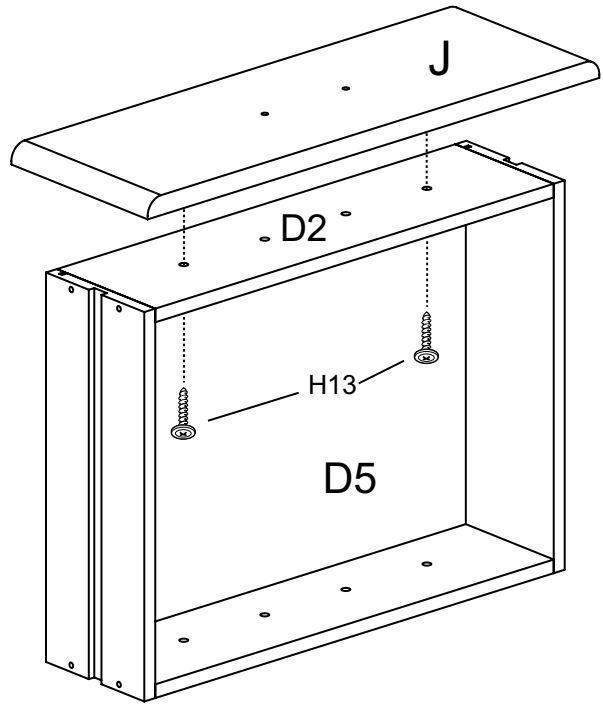

**#18**

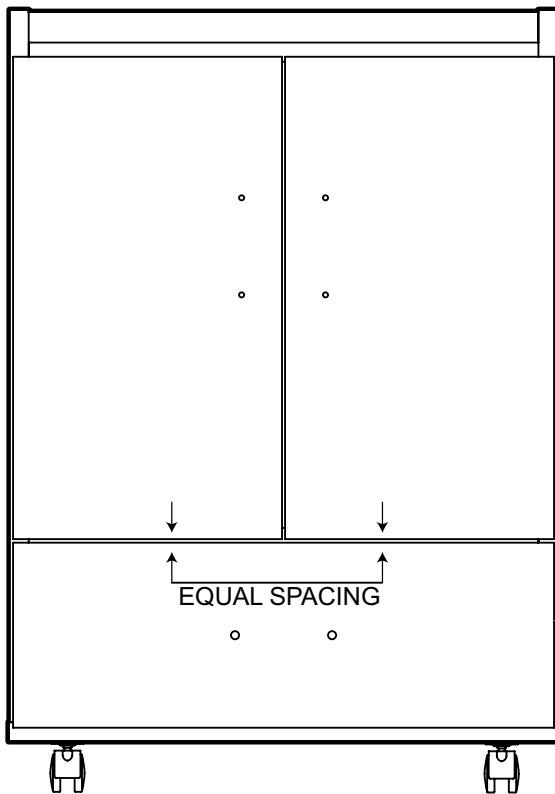

With the drawer in place, check to insure that the Drawer Front (J) is aligned level and with equal spacing at the edges.

If the Drawer Front needs adjustment, loosen Washer Head Screws (H13) slightly, move Drawer Front to the correct position and retighten screws.

LEVEL

FRONT  
ALIGNED  
WITH SIDES

**#19**

When adjusted, attach a Handle (H14) to the Drawer Front (J) using two 1-3/4" Washerhead Screws (H16) as shown.

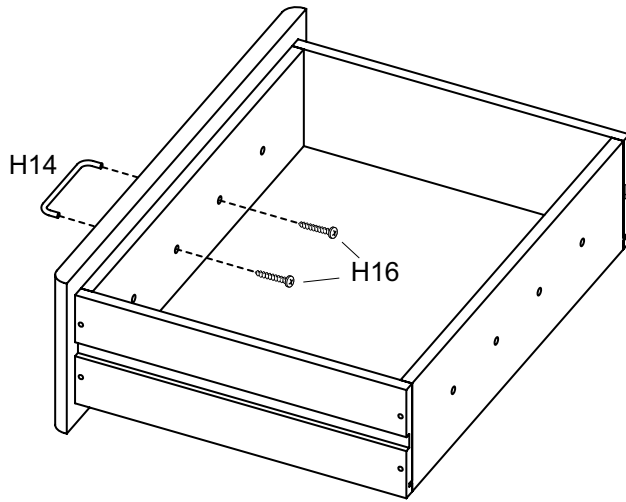

H16



H15

Attach a Handle (H14) to each Door (I) using two 1-1/4" Panhead Screws (H15) as shown.

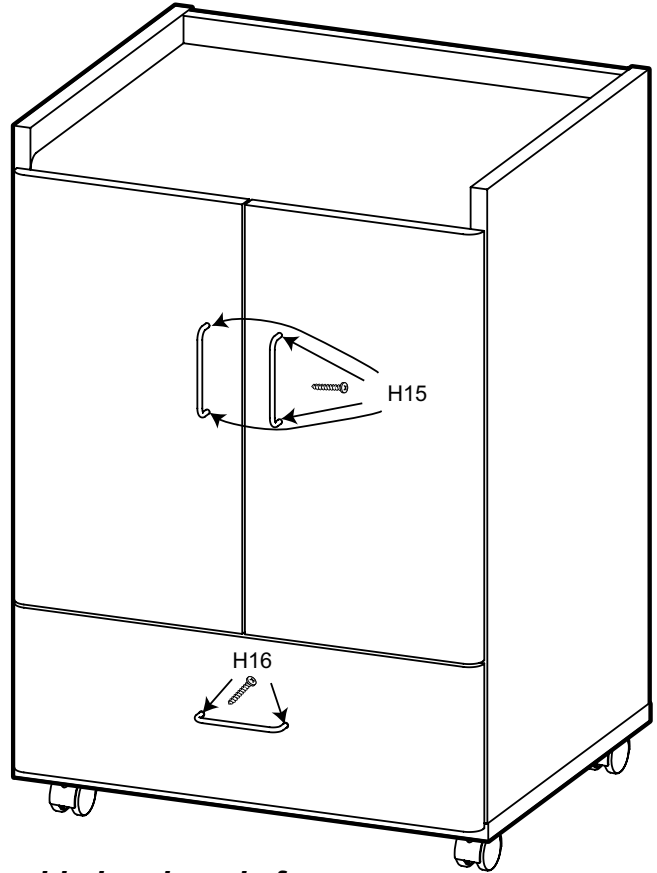

***Your Coffee Bar is now fully assembled and ready for use.***